

# CB22110A-V00CS

Continuous Conduction Mode (CCM)  
Interleave Boost Reactor

Rev. A  
Sep 8, 2011

## Features

- CCM interleave 2 Boost Inductors In 1 Reactor
- High Efficiency, Especially Over Light Load
- Integrated Magnetics
- Silence Solution
- Vertical Core Assembly, Reducing PCB Space
- Compact Size
- Competitive Cost

## Typical Application

### ○ 2500W CCM PFC Application

Input Voltage	220Vac/50Hz
Output Voltage	Vin_pk+25V
Operating Frequency	30KHz
Output Power	2500W
Power Factor	More Than <b>0.99</b>
Cooling Condition	Natural Cooling, No Fan

## Outline

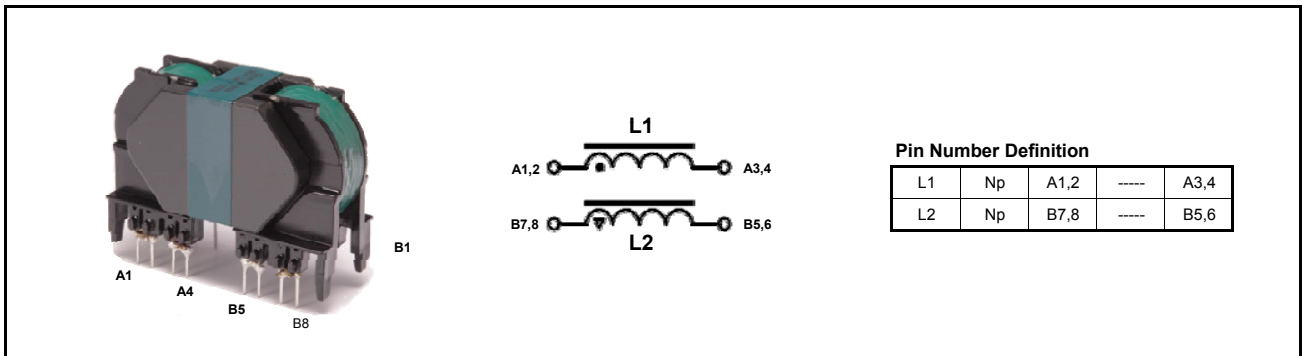

## L-I Characteristics (As Reference)

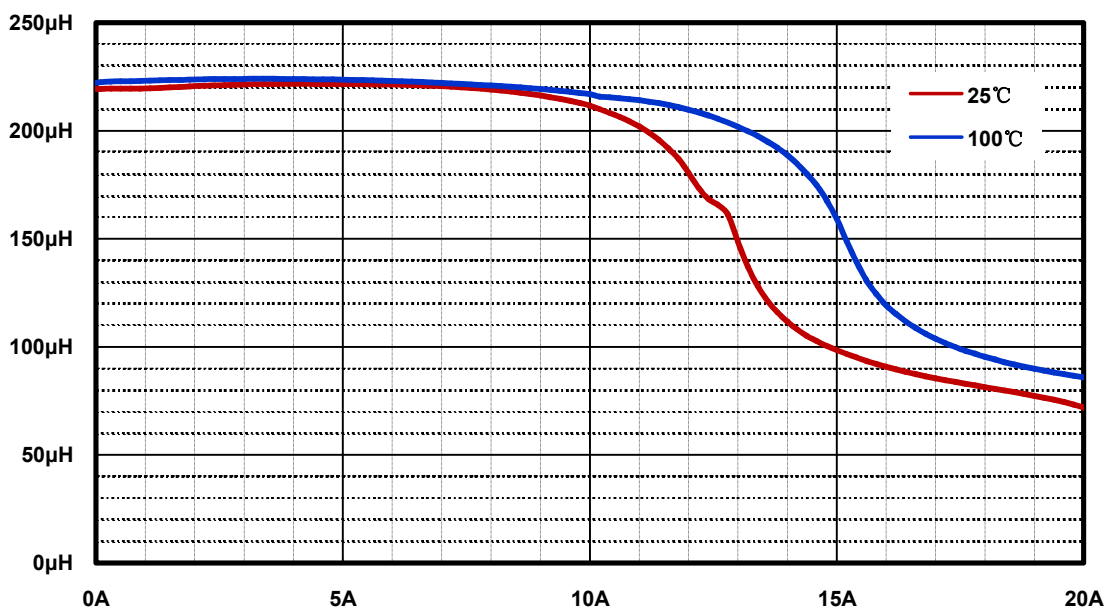

## Electric Characteristics & Specification

Items	Testing Condition	Texting Point	Specification
Inductance	100KHz, 1V at 25°C HP4284 or Equivalent	L1, L2	220 $\mu$ H $\pm$ 10% at 0A
DC Resistance	at 25°C, HIOKI AD-5521 or Equivalent	Coil1, Coil2 (Np)	52.0m $\Omega$ typ. 62.4m $\Omega$ max.
		Coil3, Coil4 (Ns)	----
Turns Ratio	----	Np:Ns	----
Dielectric Strength	EXTECH 7142 or Equivalent	Coil - Coil	AC 0.5KV, 1Min. <2mA
		Coil - Core	AC 0.5KV, 1Min. <2mA
Insulation Resistance	EXTECH 7142 or Equivalent	Coil - Coil	DC 0.5KV, >100M $\Omega$
		Coil - Core	DC 0.5KV, >100M $\Omega$
Operating Temperature	Class B Insulation, -25°C~130°C		
Storage Temperature	-25°C~75°C		
Dimension (mm)	L64 × W31 × H49		
Weight (g)	200 typ.		

## Outline Dimensional Drawing

